

## BASTUCK PRODUCT INFORMATION

EDITION 12/24 | 21.03.2024

### BMW M2 (G87) 2021 onwards

### SPORTS EXHAUST SYSTEM

The BMW M2 is the high-performance sports car in the BMW 2 Series. With its athletic looks, it also makes no secret of its performance, which was the best prerequisite for the design of our BASTUCK sports exhaust system for the BMW M2 (G87). It consists of a pair of connection tubes and the rear silencer. This is available in two versions for the standard exhaust flap.

In the super-sporty Quattro RACE S version, there are two twin tailpipes on the right and left (Ø 110 mm, 25° slanted) in RACE look, which provide a sportier and optimised look for the rear end. In the Quattro Carbon S variant, the tailpipes have exactly the same design (twin tailpipes, Ø 110 mm LH+RH, carbon fibre, 25° angled, in RACE look), but are also fitted with a carbon fibre cover, which contributes to a more refined look.

The BASTUCK sports exhaust system not only provides additional athletic accents on the BMW M2 (G87), the performance measurement also shows an optimisation compared to the standard system: plus 2.8 KW and 5.8 NM\*.

We also offer an optional replacement pipe for the front silencer for this vehicle (this item is not authorised for use on public roads - for racing purposes only).



- » Sports exhaust system with ECE homologation
- » Performance increase by 2,8 KW and 5,8 NM \*)
- » Available in two tailpipe variants

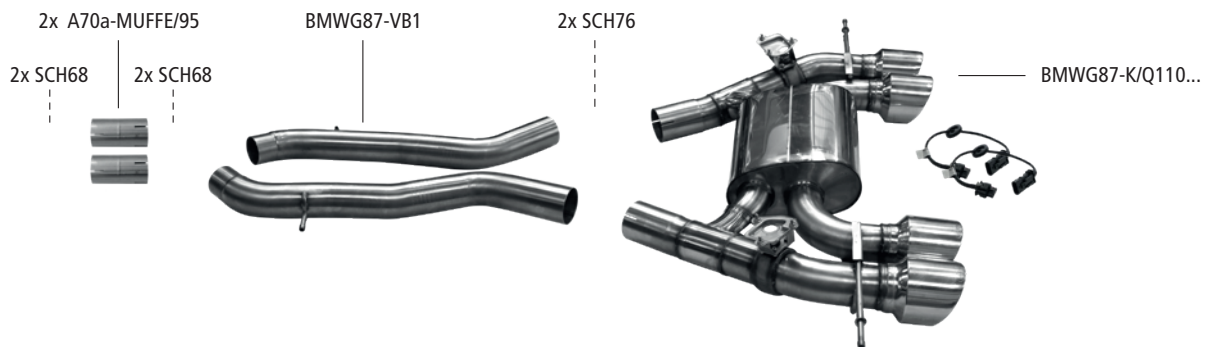

| BMW M2 G87 from 2021 onwards | rear silencer plus connecting pipes | rear silencer with double tailpipe 2x Ø 110 mm LH+RH (in RACE look), for standard flap control |

\*) Ref-vehicle: BMW M2 G87 338 KW / 6250 rpm, entry measurement: 289.6.1 KW / 575.7 NM; measurement with sports exhaust system 392.4 KW / 581.5 NM, increase by 2.8 KW / 5.8 NM

**Endschalldämpfer + Verbindungsrohre**  
(als Ersatz für Serien-Endschalldämpfer)  
mit 2 Endrohrvarianten

**Silencieux arrière + tuyaux de liaison** (en  
remplacement du silencieux arrière d'origine)  
avec 2 variantes de sorties

**Rear silencer + link pipes**  
(replacing the original rear silencer)  
in 2 tailpipe variations

**Silenciador trasero + tubos de conexión**  
(como sustituto del silenciador estándar)  
con 2 variantes de tubo de escape

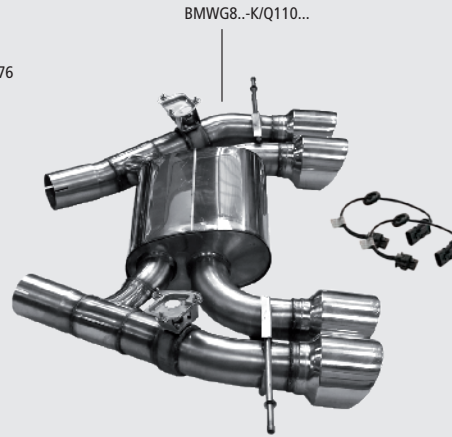
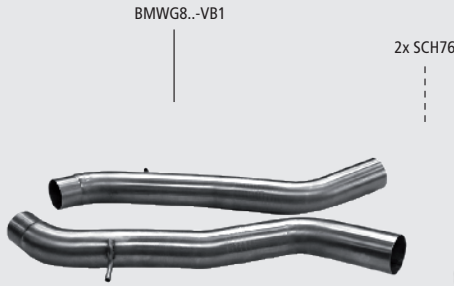
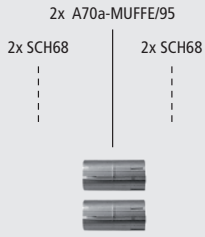

**Ersatzrohr für  
Vorschalldämpfer**

(Dieser Artikel ist nicht für die Nutzung  
im öffentlichen Straßenverkehr zulässig  
– Einsatz nur für Rennsportzwecke!)

**Tuyau de remplacement  
pour silencieux avant**

(Ce produit n'est pas homologué  
sur voie publique – uniquement pour  
l'usage sportif!)

**Tube replacing  
front silencer**

(This article is not approved for use in  
public road traffic – exclusive use for  
racing purposes!)

**Tubo de sustitución  
para el silenciador delantero**

(Este producto no está permitido para la  
circulación por las vías públicas – única-  
mente para el automovilismo!)

2x SCH68



BMWG87-1P



**Quattro RACE S**

Ø 110 mm, 25° schräg  
für Serien Abgasklappen  
pour clapets d'échappement de série  
for serial exhaust flaps  
para válvulas de escapes de serie

**Befestigungsmaterial**

**Pièces de fixation**

**Fixing parts**

**Piezas de fijación**

SCH68

SCH76



**Quattro Carbon S**

Ø 110 mm, 25° schräg  
für Serien Abgasklappen  
pour clapets d'échappement de série  
for serial exhaust flaps  
para válvulas de escapes de serie

○	76 mm		○	

## M2 G87 / M3 G80/ G81/ M4 G82/ G83

ab Bj. / après / desde 2021 onwards

<b>Verwendung</b> Die Edelstahl-Auspuffanlage ist zum Anbau an folgende Fahrzeuge geeignet: <b>Utilisation</b> Les échappements inox peuvent se monter sur les véhicules suivants:			<b>Application</b> The stainless steel exhaust is suitable for the following cars: <b>Utilización</b> El sistema de escape en acero inoxidable está previsto para los siguientes vehículos:		
<b>Typ</b>		<b>ABE-Nr./Gen.-Nr.</b>	<b>Verkaufsbezeichnung</b>		
Type		N° série	Type véhicule		
Tipo		EEC-No	car type		
Tipo de vehículo		Numéro de série	Tipo de vehículo		
<b>Motortyp</b>	<b>Hubraum</b>	<b>Nennleistung</b>	<b>Motortyp</b>	<b>Hubraum</b>	<b>Nennleistung</b>
Type moteur	Cylindrée	Puissance nominale	Type moteur	Cylindrée	Puissance nominale
Engine type	Capacity	Nominal power	Engine type	Capacity	Nominal power
Tipo de motor	Cilindrada (cm³)	Potencia nominal (KW/min)	Tipo de motor	Cilindrada (cm³)	Potencia nominal (KW/min)
<b>G2M</b>		<b>e1*2018/858*00211*..</b>	<b>BMW M2</b>		
S58B30A/Otto	2993	338/6250			
<b>G234M</b>		<b>e1*2018/858*00003*..</b>	<b>BMW M3 BMW M4</b>		
S58B30B/Otto	2993	353/6250	S58B30A/Otto	2993	375/6250

Artikel-Nr. N° Référence Article No Número del artículo	Bezeichnung	Description	Description	Descripción
BMWG87-1P	Ersatzrohr für Vorschall-dämpfer BMW M2 (Dieser Artikel ist nicht für die Nutzung im öffentlichen Straßenverkehr zulässig – Einsatz nur für Rennsportzwecke!)	Tuyau de remplacement pour silencieux central BMW M2 (Ce produit n'est pas homologué sur voie publique – uniquement pour l'usage sportif!)	Tube replacing centre silencer BMW M2 (This article is not approved for use in public road traffic – exclusive use for racing purposes!)	Tubo que sustituye el silenciador central BMW M2 (Este producto no está permitido para la circulación por las vías públicas – únicamente para el automovilismo!)
A70a-MUFFE/95	Rohrverbinder Ø 70 mm auf Ø 70 mm/ 95 mm lang	Connecteur de tube Ø 70 mm sur Ø 70 mm/ 95 mm de long	Tube connector Ø 70 mm to Ø 70 mm/ 95 mm long	Conector de tubo Ø 70 mm a Ø 70 mm/ 95 mm de longitud
BMWG87-VB1	Paar Verbindungsrohre BMW M2	Paire de tuyaux de liaison BMW M2	Pair of link pipes BMW M2	Par de tubos de conexión BMW M2
BMWG80-VB1	Paar Verbindungsrohre BMW M3/M4	Paire de tuyaux de liaison BMW M3/M4	Pair of link pipes BMW M3/M4	Par de tubos de conexión BMW M3/M4
<b>Quattro RACE S</b>				
BMWG87-K/Q110RS	Endschalldämpfer mit Doppel-Endrohr Ø 110 mm LH+RH, 25° schräg, im RACE Look, für Serien-Abgasklappen BMW M2	Silencieux arrière avec double sortie Ø 110 mm LH+RH, oblique de 25°, en look RACE, pour les clapets d'échappement de série BMW M2	Rear silencer with twin tailpipe Ø 110 mm LH+RH, 25° oblique, in RACE look, for serial exhaust flaps BMW M2	Silenciador trasero con tubo de escape doble Ø 110 mm LH+RH, 25° de oblicuidad, en óptica RACE, para válvulas de escapes de serie BMW M2
BMWG80-K/Q110RS	Endschalldämpfer mit Doppel-Endrohr Ø 110 mm LH+RH, 25° schräg, im RACE Look, für Serien-Abgasklappen BMW M3/M4	Silencieux arrière avec double sortie Ø 110 mm LH+RH, oblique de 25°, en look RACE, pour les clapets d'échappement de série BMW M3/M4	Rear silencer with twin tailpipe Ø 110 mm LH+RH, 25° oblique, in RACE look, for serial exhaust flaps BMW M3/M4	Silenciador trasero con tubo de escape doble Ø 110 mm LH+RH, 25° de oblicuidad, en óptica RACE, para válvulas de escapes de serie BMW M3/M4
<b>Quattro Carbon S</b>				
BMWG87-K/Q110CS	Endschalldämpfer mit Doppel-Endrohr Ø 110 mm LH+RH, Carbon, 25° schräg, im RACE Look, für Serien-Abgasklappen BMW M2	Silencieux arrière avec double sortie Ø 110 mm LH+RH, en carbone, oblique de 25°, en look RACE, pour les clapets d'échappement de série BMW M2	Rear silencer with twin tailpipe Ø 110 mm LH+RH, Carbon, 25° oblique, in RACE look, for serial exhaust flaps BMW M2	Silenciador trasero con tubo de escape doble Ø 110 mm LH+RH, carbono, 25° de oblicuidad, en óptica RACE, para válvulas de escapes de serie BMW M2
BMWG80-K/Q110CS	Endschalldämpfer mit Doppel-Endrohr Ø 110 mm LH+RH, Carbon, 25° schräg, im RACE Look, für Serien-Abgasklappen BMW M3/M4	Silencieux arrière avec double sortie Ø 110 mm LH+RH, en carbone, oblique de 25°, en look RACE, pour les clapets d'échappement de série BMW M3/M4	Rear silencer with twin tailpipe Ø 110 mm LH+RH, Carbon, 25° oblique, in RACE look, for serial exhaust flaps BMW M3/M4	Silenciador trasero con tubo de escape doble Ø 110 mm LH+RH, carbono, 25° de oblicuidad, en óptica RACE, para válvulas de escapes de serie BMW M3/M4
SCH68	Auspuffschelle Edelstahl Ø 68 - 73 mm	Collier de montage inox Ø 68 - 73 mm	Stainless steel clamp Ø 68 - 73 mm	Abrazadera de escape Ø 68 - 73 mm
SCH76	Auspuffschelle Edelstahl Ø 76 - 79 mm	Collier de montage inox Ø 76 - 79 mm	Stainless steel clamp Ø 76 - 79 mm	Abrazadera de escape Ø 76 - 79 mm