



BASTUCK Product Information

Edition 45/13

6th november 2013

BASTUCK sports exhaust system for BMW 4 series F32

- now available for the BMW 4: XL system (76 mm)
- with EG-homologation
- improved performance by 8,5 KW and 11 NM*

The popular BASTUCK XL sports exhaust system for the BMW 3 is now also available for the BMW 4 series. A pipe diameter of 76 mm, five sporty tail pipe versions as well as an improved performance by 8.5 KW and 11 NM are a few of the clear advantages that our system brings along.

The entire system for the BMW 4 consists of a front silencer and a rear silencer that is available with five different sporty tail pipe versions just like for the BMW 3. We offer the Twin system with single tail pipe LH and RH (each Ø 90 mm, straight or cut 30° crooked) and three sporty double variants (each Ø 76 mm, straight or cut 20° crooked, with or without inward curl).

Our new 200-cells tuning catalytic converters are now available for the different models of the BMW 4. The tuning catalytic converter for 1.6 l engine complies with the current Euro 5 standard.

Our product range for the BMW 4 is further enhanced by a tube replacing the front silencer (without TÜV-approval).

You can achieve a perfect visual upgrade by mounting our high-quality rear valance insert for RH/LH systems, which you can find in our body styling assortment.

The new BASTUCK system is compatible with different models. Please refer to the appropriate table in the catalogue for further indication on which models the system may be mounted.



*) reference vehicle 235 KW/ 5800 rpm, initial gauging: 244,5 KW and 452 Nm (with BASTUCK sports exhaust system and series catalytic converter)

Sports exhaust system Ø 76 mm (fitted to catalytic converter)

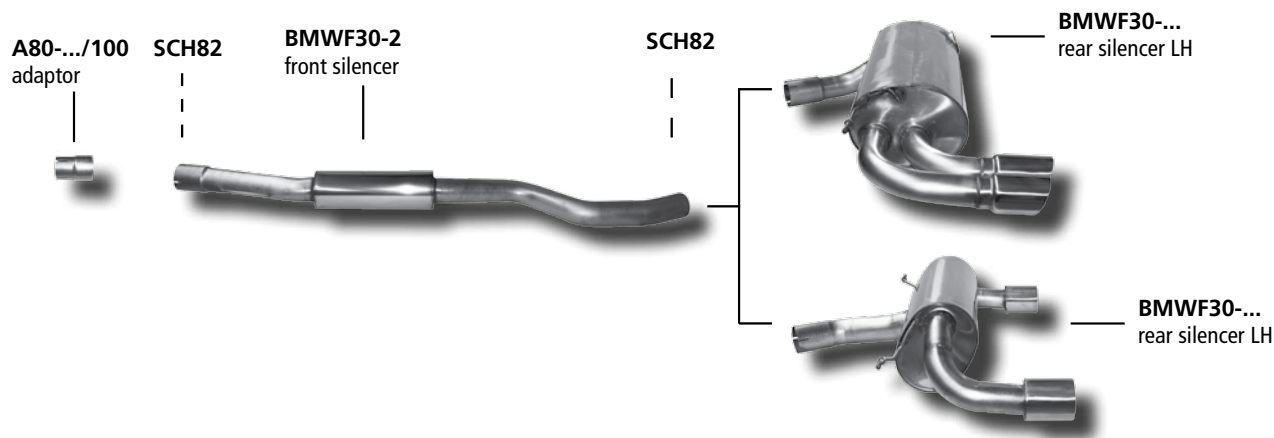

MAHA LEISTUNGS-DIAGNOSE

Bastuck & Co GmbH
Heeresstrasse West
66822 Lebach

KFZ-Typ : KW 235 / 5800
Motor-Typ : Otto Motor
Kennzeichen : BMW M135 F 20 Sp. Anl.
Prüfer : Klos Patrik

Datum : 26.10.12

Uhrzeit : 02:28

Programm-Version V 1.40 Realer-Version V 1.10 Meßbox-Version V 1.05

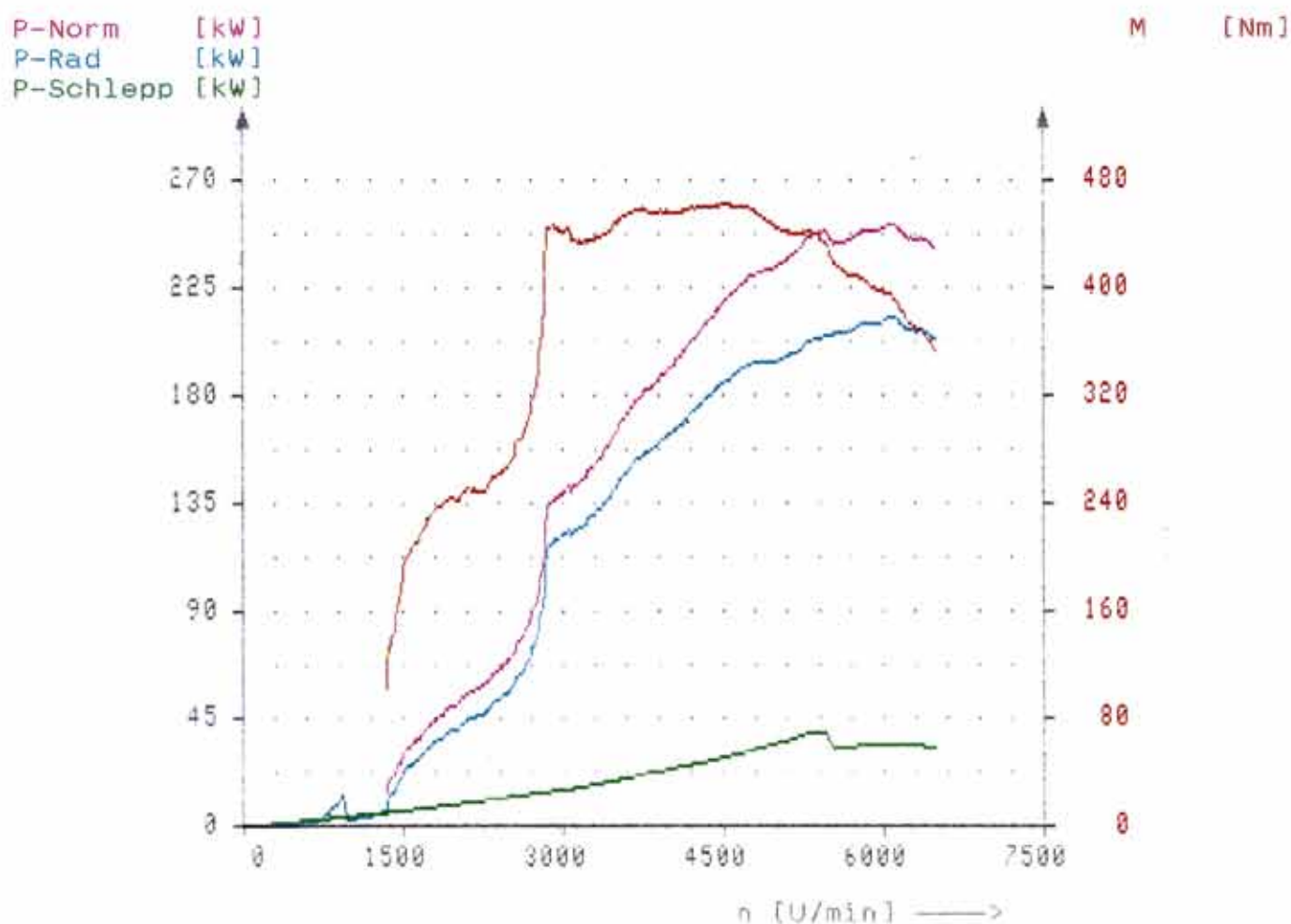

LEISTUNGS-DATEN:

Norm-Leistung P-Norm : 253,0 kW (344,0 PS)
Motorleistung P-Mot : 248,0 kW (337,2 PS)
Radleistung P-Rad : 213,5 kW (290,3 PS)
Schleppleistung P-Schlepp : 34,5 kW (46,9 PS)
Maximale Leistung bei 226 km/h bzw. 6100 U/min

Drehmoment M : 463 Nm
Maximales Drehmoment bei 165 km/h bzw. 4460 U/min

Maximale Geschwindigkeit : 242 km/h
Maximale Drehzahl : 6530 U/min

Luftdruck : 983 mbar Lufttemperatur : 13 °C
Druck 1 : 0 mbar Öltemperatur : -- °C
Druck 2 : 0 mbar Abgastemperatur : -- °C

Kompletanlage (ab Kat)
mit 5 Endrohrvarianten

Ligne complète (après catalyseur)
en 5 types de sortie

Complete system (behind catalytic converter)
in 5 tailpipe variations

Sistema entero (después del catalizador)
con 5 variantes de salidas del escape

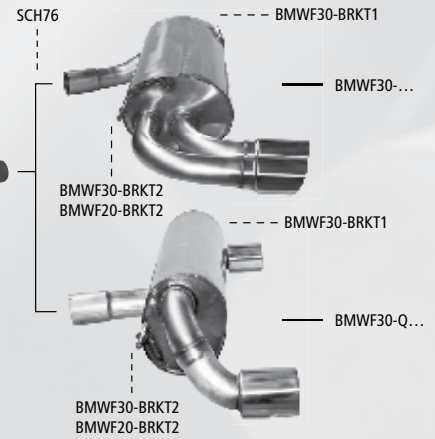
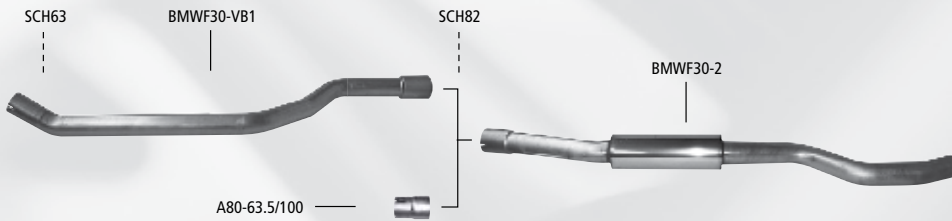

Sportkatalysator
Kat-Ersatzrohr

Catalyseur sport /
Tuyau de remplacement
pour catalyseur

Sport catalyst /
Tube replacing catalyst

Catalizador deportivo /
tubo de replazamiento
para el catalizador

1.6l Turbo



Endschalldämpfer
plus Verbindungsrohr

Silencieux arrière
plus tuyau de liaison

Rear silencer
plus link pipe

Silencioso trasero
con tubo de conexión

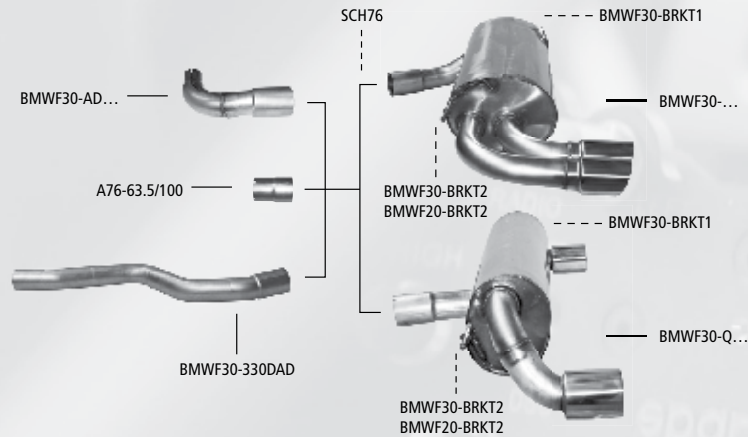

Double
Ø 76 mm



Double E
Ø 76 mm



Double S
Ø 76 mm

Ersatzrohr für
Vorschalldämpfer
(ohne TÜV)

Tuyau de remplacement
pour silencieux avant
(non homologué TÜV)

Tube replacing
front silencer
(without TÜV approval)

Tubo de replazamiento
para el primero silencioso
(sin ITV)



Twin RACE
Ø 90 mm

Heckschürzenansatz

Jupe de remplacement

Rear valance insert

Faldón trasero



Mehr / Plus / More INFO
BODYSTYLING
CATALOG

Befestigungsmaterial

Pièces de fixation

Fixing parts

Material de fijación



Twin RACE S
Ø 90 mm

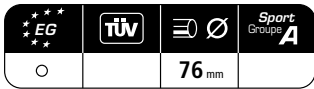

3er (F30) / 4er (F32) 1.6l Turbo + Diesel

B

Verwendung Die Edelstahl-Auspuffanlage ist zum Anbau an folgende Fahrzeuge geeignet: Utilisation Les échappements inox peuvent se monter sur les véhicules suivants:			Application The stainless steel exhaust is suitable for the following cars: Utilización Se puede montar el sistema de escape hecho de acero inoxidable a los vehículos siguientes:		
Typ Type Type Tipo		ABE-Nr./Gen.-Nr. N° série EEC-No Número de serie		Verkaufsbezeichnung Type véhicule Car type Tipo de vehículo	
Motor Type moteur Engine type Tipo de motor	Hubraum Cylindre Capacity Cubicaje (cm³)	Nennleistung Puissance Max. power Potencia (KW/min)	Motor Type moteur Engine type Tipo de motor	Hubraum Cylindre Capacity Cubicaje (cm³)	Nennleistung Puissance Max. power Potencia (KW/min)
3L e1*2007/46*0314*.. ab NT 05		BMW 3er Reihe (Limousine)			
N47D20C/Diesel	1995	85/4000	N47D20C/Diesel	1995	135/4000
N47D20C/Diesel	1995	100/4000	N47D20C/Diesel	1995	147/4000
N13B16A/Otto	1598	100/4400	N47D20D/Diesel	1995	155/4400
N47D20C/Diesel	1995	105/4000	N47D20D/Diesel	1995	160/4400
N47D20C/Diesel	1995	120/4000	N57D30A/Diesel	2993	190/4000
N19B16A/Otto	1598	125/4800			
3K e1*2007/46*0315*.. ab NT 06		BMW 3er Reihe (Touring)			
N47D20C/Diesel	1995	85/4000	N47D20C/Diesel	1995	147/4000
N47D20C/Diesel	1995	100/4000	N47D20D/Diesel	1995	155/4400
N13B16A/Otto	1598	100/4400	N47D20D/Diesel	1995	160/4400
N47D20C/Diesel	1995	120/4000	N57D30A/Diesel	2993	150/4000
N57D20C/Diesel	1995	120/4000	N57D30A/Diesel	2993	210/4000
N47D20C/Diesel	1995	135/4000			

Hinweis:
 Bei 1.6l Turbo Modellen kann der Endschalldämpfer auch alleine montiert werden! Zur Montage des Endschalldämpfers werden das Verbindungsrohr BMWF30-AD52.5 und die Halter BMWF30-BRK11 (RH) und BMWF30-BRK12 (LH) benötigt. Bei Diesel Modellen kann nur der Endschalldämpfer alleine montiert werden. Zur Montage des Endschalldämpfers werden das Verbindungsrohr BMWF30-AD55.5 (beim 4 Zyl. Diesel) bzw. das Verbindungsrohr BMWF30-330DAD (beim 6 Zyl. Diesel) und die Halter BMWF30-BRK11 (RH) und BMWF30-BRK12 (LH) benötigt. Bei Fahrzeugen mit orig. Endrohr(en) nur LH, die keine M-Heckschürze serienmäßig haben, wird bei der Montage des Endschalldämpfers BMWF30-Q90R oder BMWF30-Q90RS empfohlen die BMWF30-HE1 (nur 3er F30) zu verwenden. Bei Fahrzeugen mit orig. Endrohr(en) nur LH, die serienmäßig eine M-Heckschürze haben, wird bei der Montage des Endschalldämpfers BMWF30-Q90R oder BMWF30-Q90RS empfohlen die BMWF30-HE2 (bei 3er F30) oder BMWF32-HE2 (bei 4er F32) zu verwenden.

Remarque:
 Sur les modèles 1.6l Turbo le silencieux arrière peut également être monté seul ! Pour monter le silencieux il est nécessaire d'utiliser le tuyau de liaison BMWF30-AD52.5 et les supports BMWF30-BRK11 (RH) et BMWF30-BRK12 (LH). Sur les modèles diesels il est uniquement possible de monter le silencieux arrière seul. Il est indispensable d'utiliser le tuyau de liaison BMWF30-AD55.5 (pour Diesel 4 cyl.) ou le tuyau de liaison BMWF30-330DAD (pour Diesel 6 cyl.) et les supports BMWF30-BRK11 (RH) et BMWF30-BRK12 (LH). Sur les modèles avec sortie originale LH sans jupe arrière série M d'origine, nous recommandons d'utiliser le BMWF30-HE1 (uniquement série 3 F30) lors du montage des silencieux arrière BMWF30-Q90R ou BMWF30-Q90RS. Sur les modèles avec sortie originale LH avec une jupe arrière série M d'origine, nous recommandons d'utiliser le BMWF30-HE2 (pour série 3 F30) ou BMWF32-HE2 (pour série 4 F32) lors du montage des silencieux arrière BMWF30-Q90R ou BMWF30-Q90RS.

Attention:
 On 1.6l Turbo models the rear silencer can be mounted on its own! When mounting the silencers the link pipe BMWF30-AD52.5 and the brackets BMWF30-BRK11 (RH) and BMWF30-BRK12 (LH) are required. On diesel models it's only possible to mount the rear silencers on their own. The link pipe BMWF30-AD55.5 (for 4 cyl. Diesel) or the link pipe BMWF30-330DAD (for 6 cyl. Diesel) and the brackets BMWF30-BRK11 (RH) and BMWF30-BRK12 (RH) are required. On models with original exit LH without original M series rear valance, we recommend to use the BMWF30-HE1 (only serie 3 F30) when mounting the rear silencers BMWF30-Q90R or BMWF30-Q90RS. On models with original exit LH with an original M series rear valance, we recommend to use the BMWF30-HE2 (for serie 3 F30) or BMWF32-HE2 (for serie 4 F32) when mounting the rear silencers BMWF30-Q90R or BMWF30-Q90RS.

Atención:
 En cuanto a los modelos turbo con motor de 1.6l es posible montar solamente el silenciador trasero! Para el montaje del silenciador trasero el tubo de conexión BMWF30-AD52.5 y los soportes adicionales BMWF30-BRK11 (RH) y BMWF30-BRK12 (LH) son necesarios. En cuanto a los modelos Diesel, solamente el silenciador trasero se puede montar solo. Al montar el silenciador trasero el tubo de conexión BMWF30-AD55.5 (para 4 cilindro Diesel) respectivamente el tubo de conexión BMWF30-330DAD (para 6 cilindro Diesel) y los soportes BMWF30-BRK11 (RH) y BMWF30-BRK12 (LH) son necesarios. En los modelos con salida original LH y sin faldón trasero original de la serie M, recomendamos utilizar el BMWF30-HE1 (sólo serie 3 F30) al montar los silenciadores traseros BMWF30-Q90R o BMWF30-Q90RS. En los modelos con salida LH original con faldón trasero original de la serie M, recomendamos utilizar el BMWF30-HE2 (para la serie 3 F30) o BMWF32-HE2 (para la serie 4 F32) al montar los silenciadores traseros BMWF30-Q90R o BMWF30-Q90RS.

Artikel-Nr. N° Référence Article No Número del artículo	Bezeichnung	Description	Description	Descripción
BMWF20-KAT	Sportkatalysator (mit ECE Zulassung) 1.6l Turbo	Catalyseur Sport (homologué CE) 1.6l Turbo	Sport Catalyst (with EU approval) 1.6l Turbo	Catalizador deportivo (con aprobación UE) 1.6l Turbo
BMWF20-DP	Kat-Ersatzrohr (ohne TÜV) 1.6l Turbo	Tuyau de remplacement pour catalyseur (non homologué TÜV) 1.6l Turbo	Tube replacing catalyst (without TÜV approval) 1.6l Turbo	Tubo de replazamiento para el catalizador (sin ITV) 1.6l Turbo
BMWF30-VB1 A80-65.5/100	Verbindungsrohr vorne 1.6l Turbo (3er F30) 1.6l Turbo (4er F32)	Tuyau de liaison avant 1.6l Turbo (F30 série 3) 1.6l Turbo (F32 série 4)	Front link pipe 1.6l Turbo (F30 serie 3) 1.6l Turbo (F32 serie 4)	Tubo de conexión 1.6l Turbo (F30 serie 3) 1.6l Turbo (F32 serie 4)
BMWF30-2	Vorschalldämpfer außer Diesel	Silencieux avant sauf Diesel	Front silencer except Diesel	Silencioso primero excepto Diesel
BMWF30-2P	Ersatzrohr für Vorschalldämpfer außer Diesel (ohne TÜV)	Tuyau de remplacement pour silencieux avant sauf Diesel (non homologué TÜV)	Tube replacing front silencer except Diesel (without TÜV approval)	Tubo de replazamiento para el primero silencioso primero excepto Diesel (sin ITV)
BMWF30-AD52.5 A76-63.5/100 BMWF30-AD55.5 BMWF30-330DAD	Verbindungsrohr zur Montage der Endschalldämpfer alleine 1.6l Turbo (3er F30) 1.6l Turbo (4er F32) 4 Zyl. Diesel 6 Zyl. Diesel	Tuyau de liaison pour montage des silencieux arrière seuls 1.6l Turbo (F30 série 3) 1.6l Turbo (F32 série 4) 4 cyl. Diesel 6 cyl. Diesel	Link pipe to mount the rear silencers on their own 1.6l Turbo (F30 serie 3) 1.6l Turbo (F32 serie 4) 4 cyl. Diesel 6 cyl. Diesel	Tubo de conexión para montar el silenciador trasero solo 1.6l Turbo (F30 serie 3) 1.6l Turbo (F32 serie 4) 4 cilindro Diesel 6 cilindro Diesel
Double				
BMWF30-76	Endschalldämpfer mit Doppel-Endrohr 2x Ø 76 mm	Silencieux arrière à sortie double 2x Ø 76 mm	Rear silencer with double tailpipe 2x Ø 76 mm	Silencioso trasero con doble tubo de escape, 2x Ø 76 mm
Double E				
BMWF30-76E	Endschalldämpfer mit Doppel-Endrohr 20° schräg mit Lippe 2x Ø 76 mm	Silencieux arrière à sortie double à lèvre, découpé à 20° 2x Ø 76 mm	Rear silencer with double tailpipe, cut 20° with inward curl 2x Ø 76 mm	Silencioso trasero con doble tubo de escape, cortado 20° con costilla 2x Ø 76 mm
Double S				
BMWF30-76T	Endschalldämpfer mit Doppel-Endrohr 20° schräg 2x Ø 76 mm	Silencieux arrière à sortie double découpé à 20° 2x Ø 76 mm	Rear silencer with double tailpipe, cut 20° 2x Ø 76 mm	Silencioso trasero con doble tubo de escape, cortado 20° 2x Ø 76 mm
Twin RACE				
BMWF30-Q90R	Endschalldämpfer mit Einfach-Endrohr Ø 90 mm LH + RH (im RACE Lock)	Silencieux arrière à sortie simple Ø 90 mm LH + RH (au look RACE)	Rear silencer with single tailpipe Ø 90 mm LH + RH (with RACE look)	Silenciosos trasero con una salida de tubo Ø 90 mm LH + RH (con RACE look)
Twin RACE S				
BMWF30-Q90RS	Endschalldämpfer mit Einfach-Endrohr 30° schräg geschlitten Ø 90 mm LH + RH (im RACE Lock)	Silencieux arrière à sortie simple découpé à 30° Ø 90 mm LH + RH (au look RACE)	Rear silencer with single tailpipe cut 30° Ø 90 mm LH + RH (with RACE Look)	Silenciosos trasero con una salida de tubo cortado 20° diagonal Ø 90 mm LH + RH (con RACE look)
BMWF30-BRK11 BMWF30-BRK12 BMWF20-BRK12	Zusatzhalter für Endschalldämpfer 1.6l Turbo / Diesel RH 1.6l Turbo LH Diesel LH	Support de fixation pour silencieux arrière 1.6l Turbo / Diesel RH 1.6l Turbo LH Diesel LH	Bracket for rear silencer 1.6l Turbo / Diesel RH 1.6l Turbo LH Diesel LH	Soporte para el silenciador trasero 1.6l Turbo / Diesel RH 1.6l Turbo LH Diesel LH
BMWF30-HE1 BMWF30-HE2	Heckschürzeneinsatz, mit Ausschnitt für 2 x Einfach-Endrohr BMW 3er (F30) BMW 3er (F30) mit M-Paket BMW 4er (F32)	Jupe de remplacement, avec découpe pour 2 x sorties simples BMW Serie 3 (F30) BMW Serie 3 (F30) avec kit M BMW Serie 4 (F32)	Rear valance insert with cut out for 2 x single tailpipes BMW Serie 3 (F30) BMW Serie 3 (F30) with M-Kit BMW Serie 4 (F32)	Inserción valance trasero con el recorte de 2 x salidas individuales BMW Serie 3 (F30) BMW Serie 3 (F30) con M-Kit BMW Serie 4 (F32)
SCH63 SCH76 SCH82	Auspuffschele Edelstahl Ø 63-68 mm Ø 74-79 mm Ø 80-85 mm	Collier de montage inox Ø 63-68 mm Ø 74-79 mm Ø 80-85 mm	Stainless steel clamp Ø 63-68 mm Ø 74-79 mm Ø 80-85 mm	Abrazadera de acero inoxidable Ø 63-68 mm Ø 74-79 mm Ø 80-85 mm

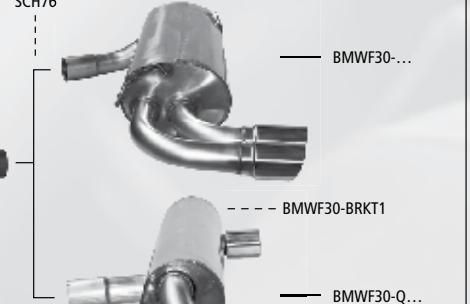

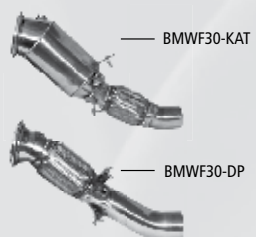
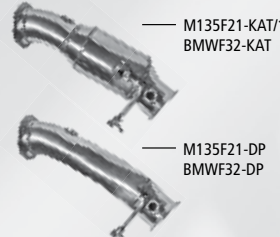
<p>Kompletanlage (ab Kat) mit 5 Endrohrvarianten</p>	<p>Ligne complète (après catalyseur) en 5 types de sortie</p>	<p>Complete system (behind catalytic converter) in 5 tailpipe variations</p>	<p>Sistema entero (después del catalizador) con 5 variantes de salidas del escape</p>
			

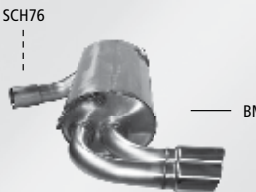
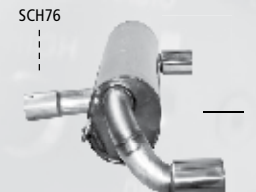
<p>Sportkatalysator / Kat-Ersatzrohr</p> <p>2.0l Turbo</p> 	<p>Catalyseur sport / Tuyau de remplacement pour catalyseur</p> <p>3.0l Turbo</p> 	<p>Sport catalyst / Tube replacing catalyst</p> <p>Catalizador deportivo / tubo de replazamiento para el catalizador</p>
--	---	--

<p>Endschalldämpfer (als Ersatz für den Serienschalldämpfer nur für 2.0l Turbo)</p> 	<p>Silencieux arrière (remplace le silencieux arrière d'origine uniquement pour 2.0l Turbo)</p> 	<p>Rear silencer (replacing the original rear silencer only for 2.0l Turbo)</p> <p>Silencioso trasero (como un sustituto de la silenciador estándar solo para 2.0l Turbo)</p>
---	---	---

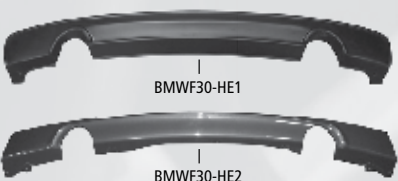
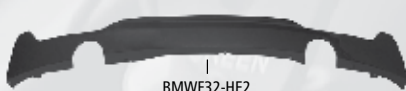
<p>Ersatzrohr für Vorschalldämpfer (ohne TÜV)</p> 	<p>Tuyau de remplacement pour silencieux avant (non homologué TÜV)</p>	<p>Tube replacing front silencer (without TÜV approval)</p> <p>Tubo de replazamiento para el primero silencioso (sin ITV)</p>
---	---	---

<p>Heckschürzenansatz</p> 	<p>Jupe de remplacement</p>	<p>Rear valance insert</p> 	<p>Faldón trasero</p>
---	------------------------------------	---	------------------------------

<p>Befestigungsmaterial</p> 	<p>Pièces de fixation</p> <p>Halter / Support de fixation / Bracket / Soporte</p> 	<p>Fixing parts</p> <p>Material de fijación</p>
--	---	---



Double
Ø 76 mm



Double E
Ø 76 mm



Double S
Ø 76 mm



Twin RACE
Ø 90 mm



Twin RACE S
Ø 90 mm

Mehr / Plus / More INFO
BODYSTYLING
CATALOG

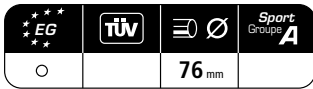

3er (F30) / 4er (F32) 2.0l + 3.0l Turbo

B

Verwendung Die Edelstahl-Auspuffanlage ist zum Anbau an folgende Fahrzeuge geeignet:		Application The stainless steel exhaust is suitable for the following cars:			
Utilisation Les échappements inox peuvent se monter sur les véhicules suivants:		Utilización Se puede montar el sistema de escape hecho de acero inoxidable a los vehículos siguientes:			
Typ Type Tipo	ABE-Nr./Gen.-Nr. N° série EEC-No Número de serie	Verkaufsbezeichnung Type véhicule Car type Tipo de vehículo			
Motor type Type moteur Engine type Tipo de motor	Hubaum Cylindré Capacité Cubicaje (cm³)	Nennleistung Puissance Max. power Potencia (KW/min)	Motor type Type moteur Engine type Tipo de motor	Hubaum Cylindré Capacité Cubicaje (cm³)	Nennleistung Puissance Max. power Potencia (KW/min)
3L		e1*2007/46*0314*.. ab NT 05		BMW 3er Reihe (Limousine)	
N20B20R/Otto	1997	135/5000	N55B30A/Otto	2979	225/5800
N20B20A/Otto	1997	180/5000	N55B30A/Otto	2979	240/5800
3K		e1*2007/46*0315*.. ab NT 06		BMW 3er Reihe (Touring)	
N20B20R/Otto	1997	135/5000	N55B30A/Otto	2979	225/5800
N20B20A/Otto	1997	180/5000	N55B30A/Otto	2979	240/5800

Hinweis:
 Bei 2.0l Turbo Modellen kann der Endschalldämpfer auch alleine montiert werden! Zur Montage des Endschalldämpfers wird kein Adapter benötigt!
 Bei 3.0l Turbo Modellen kann nur die Kompletanlage montiert werden! Zur Montage des Endschalldämpfers BMWF30-Q... wird der Halter BMWF30-BRKT1 (RH) benötigt!
 Bei Fahrzeugen mit orig. Endrohr(en) nur LH, die keine M-Heckschürze serienmäßig haben, wird bei der Montage des Endschalldämpfers BMWF30-Q90R oder BMWF30-Q90RS empfohlen die BMWF30-HE1 (nur 3er F30) zu verwenden.
 Bei Fahrzeugen mit orig. Endrohr(en) nur LH, die serienmäßig eine M-Heckschürze haben, wird bei der Montage des Endschalldämpfers BMWF30-Q90R oder BMWF30-Q90RS empfohlen die BMWF30-HE2 (bei 3er F30) oder BMWF32-HE2 (bei 4er F32) zu verwenden.

Remarque:

Sur les modèles 2.0l Turbo le silencieux arrière peut également être monté seul! Pour monter le silencieux arrière aucun adaptateur est nécessaire.
 Sur les modèles 3.0l Turbo il est uniquement possible de monter la ligne complète! Pour le montage du silencieux arrière BMWF30-Q... il est nécessaire d'utiliser en plus le support BMWF30-BRKT1 (RH).
 Sur les modèles avec sortie originale LH sans jupe arrière série M d'origine, nous recommandons d'utiliser le BMWF30-HE1 (uniquement série 3 F30) lors du montage des silencieux arrière BMWF30-Q90R ou BMWF30-Q90RS.
 Sur les modèles avec sortie originale LH avec une jupe arrière série M d'origine, nous recommandons d'utiliser le BMWF30-HE2 (pour série 3 F30) ou BMWF32-HE2 (pour série 4 F32) lors du montage des silencieux arrière BMWF30-Q90R ou BMWF30-Q90RS.

Attention:

On 2.0l Turbo models the rear silencer can be mounted on its own! To mount the rear silencers no adaptor is required.
 On 3.0l Turbo models it's only possible to mount the complete exhaust system. To mount the silencers BMWF30-Q... the bracket BMWF30-BRKT1 (RH) is required.
 On models with original exit LH without original M series rear valance, we recommend to use the BMWF30-HE1 (only serie 3 F30) when mounting the rear silencers BMWF30-Q90R or BMWF30-Q90RS.
 On models with original exit LH with an original M series rear valance, we recommend to use the BMWF30-HE2 (for serie 3 F30) or BMWF32-HE2 (for serie 4 F32) when mounting the rear silencers BMWF30-Q90R or BMWF30-Q90RS.

Atención:

En cuanto a los modelos turbo con motor de 2.0l es posible montar solamente el silenciador trasero! Para el montaje del silenciador trasero no adaptador adicional es necesario!
 En los modelos turbo 3.0l todo el sistema se puede instalar! Para el montaje del silenciador de escape BMWF30-Q... es el soporte BMWF30-BRKT1 (RH) necesidades!
 En los modelos con salida original LH y sin faldón trasero original de la serie M, recomendamos utilizar el BMWF30-HE1 (sólo serie 3 F30) al montar los silenciadores traseros BMWF30-Q90RS o BMWF30-Q90R.
 En los modelos con salida LH original con faldón trasero original de la serie M, recomendamos utilizar el BMWF30-HE2 (para la serie 3 F30) o BMWF32-HE2 (para la serie 4 F32) al montar los silenciadores traseros BMWF30-Q90R o BMWF30-Q90RS.

Artikel-Nr. N° Référence Article No Número del artículo	Bezeichnung	Description	Description	Descripción
BMW F30-KAT M135F21-KAT/1	Sportkatalysator (ohne TÜV) 2.0l Turbo 3.0l Turbo (bis Baujahr 06/2013)	Catalyseur Sport (non homologué TÜV) 2.0l Turbo 3.0l Turbo (jusqu'à 06/2013)	Sport Catalyst (without TÜV approval) 2.0l Turbo 3.0l Turbo (built before 06/2013)	Catalizador deportivo (sin ITV) 2.0l Turbo 3.0l Turbo (antes de 06/2013)
BMW F32-KAT	3.0l Turbo (ab Baujahr 06/2013)	3.0l Turbo (après 06/2013)	3.0l Turbo (built after 06/2013)	3.0l Turbo (después de 06/2013)
BMW F30-DP M135F21-DP	Kat-Ersatzrohr (ohne TÜV) 2.0l Turbo 3.0l Turbo (bis Baujahr 06/2013)	Tuyau de remplacement pour catalyseur (non homologué TÜV) 2.0l Turbo 3.0l Turbo (jusqu'à l'année 06/2013)	Tube replacing catalyst (without TÜV approval) 2.0l Turbo 3.0l Turbo (built before 06/2013)	Tubo de replazamiento para el catalizador (sin ITV) 2.0l Turbo 3.0l Turbo (antes de 06/2013)
BMW F32-DP	3.0l Turbo (ab Baujahr 06/2013))	3.0l Turbo (après 06/2013)	3.0l Turbo (built after 06/2013)	3.0l Turbo (después de 06/2013)
A80-74.5/100	Adapter Kompletanlage auf Serie (wird nur beim 2.0l Turbo benötigt) auf Ø 74.5 mm	Adaptateur ligne complète sur série (uniquement pour modèles 2.0l Turbo) pour Ø 74.5 mm	Adaptor complete system (only for 2.0l Turbo models) to Ø 74.5 mm	Adaptador para el sistema completo del sistema original (sólo para 2.0l Turbo) a Ø 74.5 mm
BMW F30-2	Vorschalldämpfer	Silencieux avant	Front silencer	Silencioso primero
BMW F30-2P	Ersatzrohr für Vorschalldämpfer (ohne TÜV)	Tuyau de remplacement pour silencieux avant (non homologué TÜV)	Tube replacing front silencer (without TÜV approval)	Tubo de replazamiento para el primero silencioso primero (sin ITV)
Double				
BMW F30-76	Endschalldämpfer mit Doppel-Endrohr 2x Ø 76 mm (außer 335i)	Silencieux arrière à sortie double 2x Ø 76 mm (hormis 335i)	Rear silencer with double tailpipe 2x Ø 76 mm (except 335i)	Silencioso trasero con doble tubo de escape, 2x Ø 76 mm (excepto 335i)
Double E				
BMW F30-76E	Endschalldämpfer mit Doppel-Endrohr 20° schräg mit Lippe 2x Ø 76 mm (außer 335i)	Silencieux arrière à sortie double à lèvre, découpé à 20° 2x Ø 76 mm (hormis 335i)	Rear silencer with double tailpipe, cut 20° with inward curl 2x Ø 76 mm (except 335i)	Silencioso trasero con doble tubo de escape, cortado 20° con costilla 2x Ø 76 mm (excepto 335i)
Double S				
BMW F30-76T	Endschalldämpfer mit Doppel-Endrohr 20° schräg 2x Ø 76 mm (außer 335i)	Silencieux arrière à sortie double découpé à 20° 2x Ø 76 mm (hormis 335i)	Rear silencer with double tailpipe, cut 20° 2x Ø 76 mm (except 335i)	Silencioso trasero con doble tubo de escape, cortado 20° 2x Ø 76 mm (excepto 335i)
Twin RACE				
BMW F30-Q90R	Endschalldämpfer mit Einfach-Endrohr Ø 90 mm LH + RH (im RACE Look)	Silencieux arrière à sortie simple Ø 90 mm LH + RH (au look RACE)	Rear silencer with single tailpipe Ø 90 mm LH + RH (with RACE look)	Silenciosos trasero con una salida de tubo Ø 90 mm LH + RH (con RACE look)
Twin RACE S				
BMW F30-Q90RS	Endschalldämpfer mit Einfach-Endrohr 30° schräg geschritten Ø 90 mm LH + RH (im RACE Look)	Silencieux arrière à sortie simple découpé à 30° Ø 90 mm LH + RH (au look RACE)	Rear silencer with single tailpipe cut 30° Ø 90 mm LH + RH (with RACE Look)	Silenciosos trasero con una salida de tubo cortado 20° diagonal Ø 90 mm LH + RH (con RACE look)
BMW F30-BRKT1	Zusatzhalter RH für Endschalldämpfer BMWF30-Q... 3.0l Turbo	Support de fixation RH pour silencieux arrière BMWF30-Q... 3.0l Turbo	Bracket RH for rear silencer BMWF30-Q... 3.0l Turbo	Soporte para el silencioso trasero RH BMWF30-Q... 3.0l Turbo
BMW F30-HE1 BMW F30-HE2	Heckschürzeneinsatz, mit Ausschnitt für 2 x Einfach-Endrohr BMW 3er (F30) BMW 3er (F30) mit M-Paket	Jupe de remplacement, avec découpe pour 2 x sorties simples BMW Serie 3 (F30) BMW Serie 3 (F30) avec kit M	Rear valance insert with cut out for 2 x single tailpipes BMW Serie 3 (F30) BMW Serie 3 (F30) with M-Kit	Inserción valance trasero con el recorte de 2 x salidas individuales BMW Serie 3 (F30) BMW Serie 3 (F30) con M-Kit
BMW F32-HE2	BMW 4er (F32)	BMW Serie 4 (F32)	BMW Serie 4 (F32)	BMW Serie 4 (F32)
SCH76 SCH82	Auspuffschelle Edelstahl Ø 74-79 mm Ø 80-85 mm	Collier de montage inox Ø 74-79 mm Ø 80-85 mm	Stainless steel clamp Ø 74-79 mm Ø 80-85 mm	Abrazadera de acero inoxidable Ø 74-79 mm Ø 80-85 mm